

# Závěsy CLIP top / CLIP top BLUMOTION - standardní využití

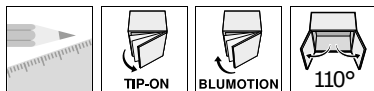

## Závěs, 110°

### Plánování

Rozměry závěsu a výpočet mezery při nastavení ze závodu (montážní podložka = 0 mm)

Přesah dvířek při plném otevření

#### Naložená dvířka

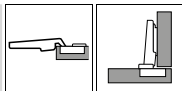

#### Polonaložená dvířka

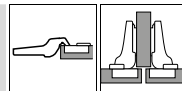

#### Vložená dvířka

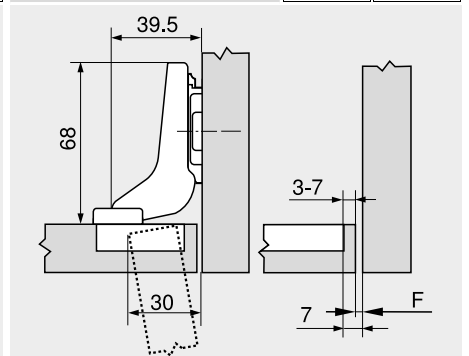
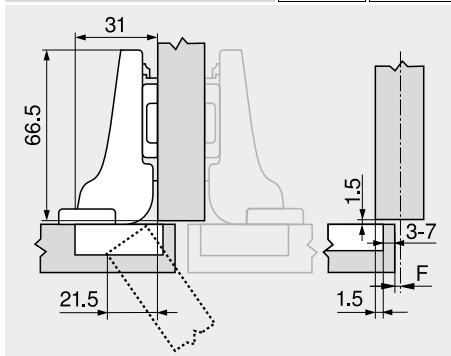
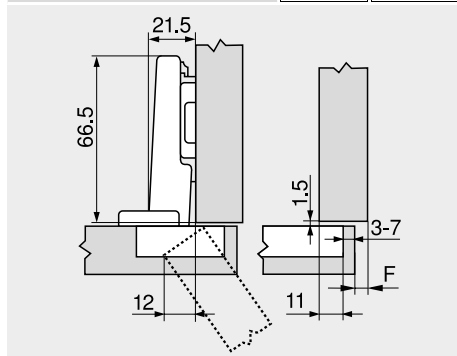
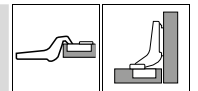

F Mezera

Pozici pro našroubování podložky odsadte o sílu dvířek +1.5 mm

### Odstup misky TB

Zvýšení montážních podložek (mm)	Přesah čela FA (mm)																				
	5	6	7	8	9	10	11	12	13	14	15	16	17	18	19	20	21	22			
0																	3	4	5	6	7
3																	3	4	5	6	7
6																	3	4	5	6	7
9																	3	4	5	6	7

Zvýšení montážních podložek (mm)	Přesah čela FA (mm)																					
	-45	-35	-25	-15	-05	0.5	1.5	2.5	3.5	4.5	5.5	6.5	7.5	8.5	9.5	10.5	11.5	12.5				
0																		3	4	5	6	7
3																		3	4	5	6	7
6																		3	4	5	6	7
9																		3	4	5	6	7

Zvýšení montážních podložek (mm)	Přesah čela FA (mm)									
	-4	-3	-2	-1	0	1	2	3	4	5
0										
3										
6										
9										

### Minimální mezera (F) pro dvířka se sraženými hranami (R = 1 mm) při nastavení ze závodu

Odstup misky TB (mm)	Síla čela FD (mm)											
	16	18	19	20	21	22	23	24	25	26	28	30
3	0.5	0.8	1.0	1.2	1.5	1.8	2.2	2.7	3.5	4.3	Δ	Δ
4	0.5	0.8	1.0	1.2	1.4	1.7	2.0	2.5	3.1	3.8	Δ	Δ
5	0.5	0.8	0.9	1.2	1.4	1.7	2.0	2.4	2.9	3.4	Δ	Δ
6	0.5	0.8	0.9	1.2	1.3	1.6	1.9	2.3	2.7	3.2	Δ	Δ
7	0.5	0.8	0.9	1.1	1.3	1.6	1.9	2.2	2.6	3.0	Δ	Δ
<b>Navíc u seřízení do stran +2 mm</b>												
	+0.2	+0.4	+0.4	+0.5	+0.5	+0.5	+0.5	+0.5	+0.5	+0.5		

Δ Doporučujeme montáž na zkoušku

### Seřízení a nastavení

Seřízení	Nastavení	Nastavení
Max. ±3.0 mm Viz. montážní podložky	±2.0 mm	+3.0 mm -2.0 mm

### Montáž našroubováním

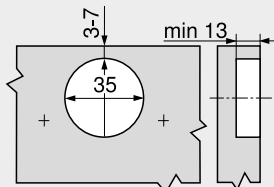

### Montáž technikou INSERTA /halisováním

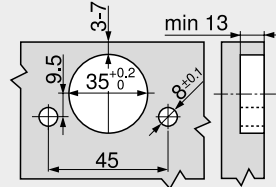

### Rozměry misky

