

	Počet křídel n / Quantity of doors n	n = 2	n = 3	n = 4	n = 5	n = 6	n = 7	n = 8
	Výška desky hP [mm] / Board height hP [mm]	hP = H-III						
	Šířka desky bP [mm] / Board width bP [mm]	bP=(S-48)/2	bP=(S-55)/3	bP=(S-62)/4	bP=(S-70)/5	bP=(S-77)/6	bP=(S-84)/7	bP=(S-91)/8
	Délka dolního, horního rámu a spojky R [mm] Upper, lower rail and connector lenght R [mm]	R = bP-23						
	Délka profilu LR [mm] / Handle lenght LR [mm]	LR = H-47						

+	Výška desky hP [mm] / Board height hP [mm]	hP = H-III						
	Šířka desky bP [mm] / Board width bP [mm]	bP=(S-48)/2	bP=(S-55)/3	bP=(S-62)/4	bP=(S-70)/5	bP=(S-77)/6	bP=(S-84)/7	bP=(S-91)/8
	Délka dolního, horního rámu a spojky R [mm] Upper, lower rail and connector lenght R [mm]	R = bP-23						
	Výška zrcadla/skla hL [mm] / Mirror height hL [mm]	hL = H-II4						
	šířka zrcadla/skla bL [mm] / Mirror width bL [mm]	bL=(S-54)/2	bL=(S-64)/3	bL=(S-74)/4	bL=(S-85)/5	bL=(S-95)/6	bL=(S-105)/7	bL=(S-115)/8
	Délka dolního, horního rámu a spojky R [mm] Upper, lower rail and connector lenght R [mm]	R = bL-20						
Délka profilu LR [mm] / Handle lenght LR [mm]	LR = H-47							

+	Výška desky hP [mm] / Board height hP [mm]	hP = H-III						
	Šířka desky bP [mm] / Board width bP [mm]	bP=(S-48)/2	bP=(S-55)/3	bP=(S-62)/4	bP=(S-70)/5	bP=(S-77)/6	bP=(S-84)/7	bP=(S-91)/8
	Délka dolního, horního rámu a spojky R [mm] Upper, lower rail and connector lenght R [mm]	R = bP-23						
	Výška zrcadla/skla hL [mm] / Mirror height hL [mm]	hL = H-I08						
	šířka zrcadla/skla bL [mm] / Mirror width bL [mm]	bL=(S-36)/2	bL=(S-37)/3	bL=(S-38)/4	bL=(S-40)/5	bL=(S-41)/6	bL=(S-42)/7	bL=(S-43)/8
	Délka dolního, horního rámu a spojky R [mm] Upper, lower rail and connector lenght R [mm]	R = bL-29						
Délka profilu LR [mm] / Handle lenght LR [mm]	LR = H-47							

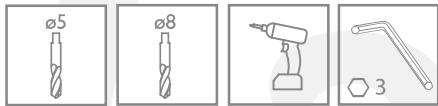
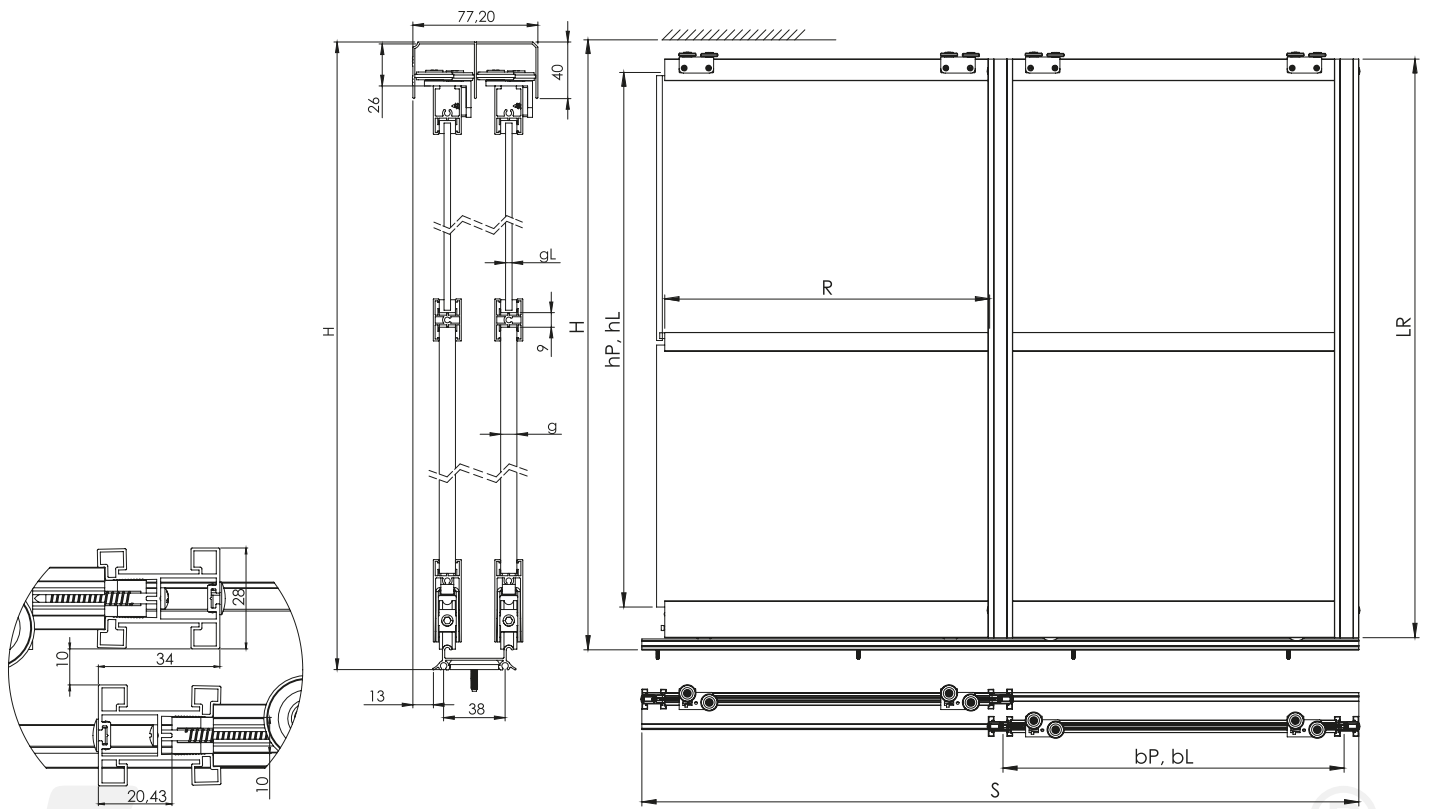

B, D, M

1

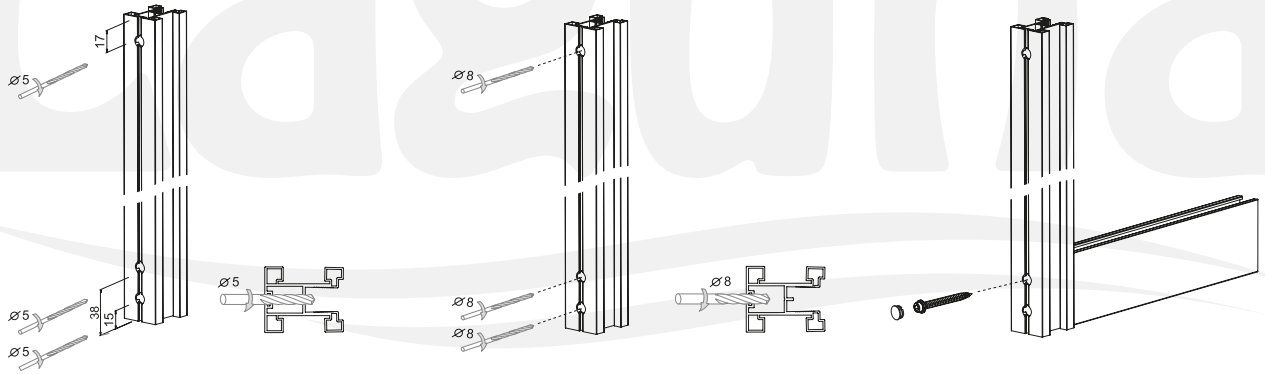

2.1

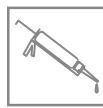
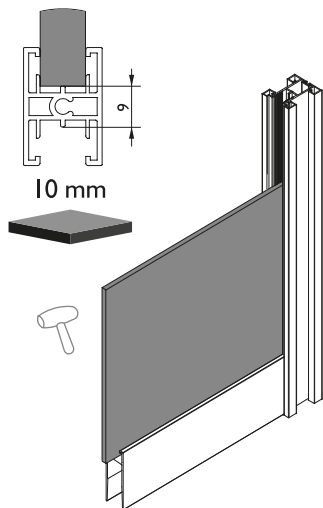

2.2

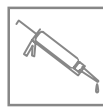
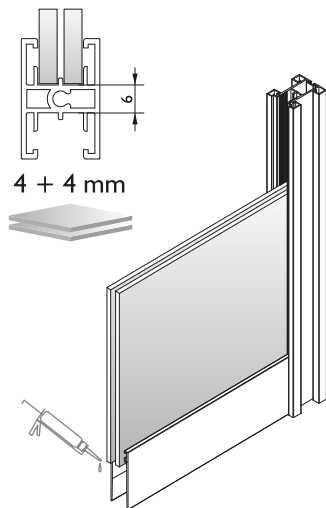

2.3

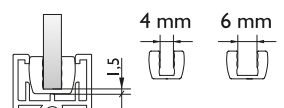
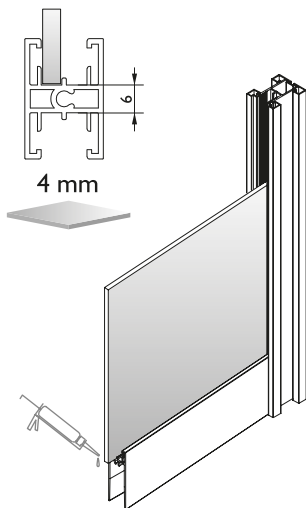

2.4

