

TWIN LAMBDA

na kolejnici RAMA
lower track RAMA

40
kg



Rama



10 mm



4/6 mm

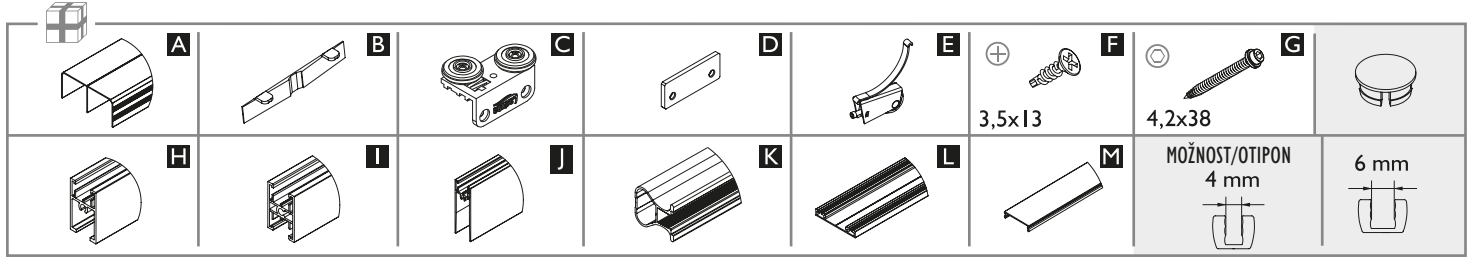
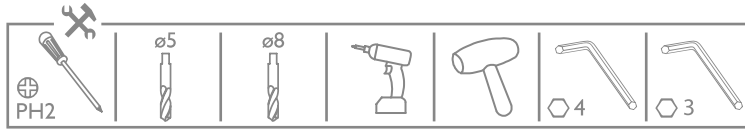

10 mm DESKA BOARD	Počet křídel n / Quantity of doors n	n = 2	n = 3	n = 4	n = 5	n = 6	n = 7	n = 8
	Výška desky hP [mm] / Board height hP [mm]	hP = H-104						
Šířka desky bP [mm] / Board width bP [mm]	$bP = (S-34)/2$	$bP = (S-31)/3$	$bP = (S-28)/4$	$bP = (S-25)/5$	$bP = (S-23)/6$	$bP = (S-19)/7$	$bP = (S-16)/8$	
Délka dolního, horního rámu a spojky R [mm] Upper, lower rail and connector length R [mm]	R = bP-23							
Délka profilu LR [mm] / Handle length LR [mm]	LR = H-40							
4, 6 mm ZRCADLO MIRROR	Počet křídel n / Quantity of doors n	n = 2	n = 3	n = 4	n = 5	n = 6	n = 7	n = 8
Výška zrcadla/skla hL [mm] / Mirror height hL [mm]	hL = H-107							
Šířka zrcadla/skla bL [mm] / Mirror width bL [mm]	$bL = (S-40)/2$	$bL = (S-40)/3$	$bL = (S-40)/4$	$bL = (S-40)/5$	$bL = (S-40)/6$	$bL = (S-40)/7$	$bL = (S-40)/8$	
Délka dolního, horního rámu a spojky R [mm] Upper, lower rail and connector length R [mm]	R = bL-20							
Délka profilu LR [mm] / Handle length LR [mm]	LR = H-40							

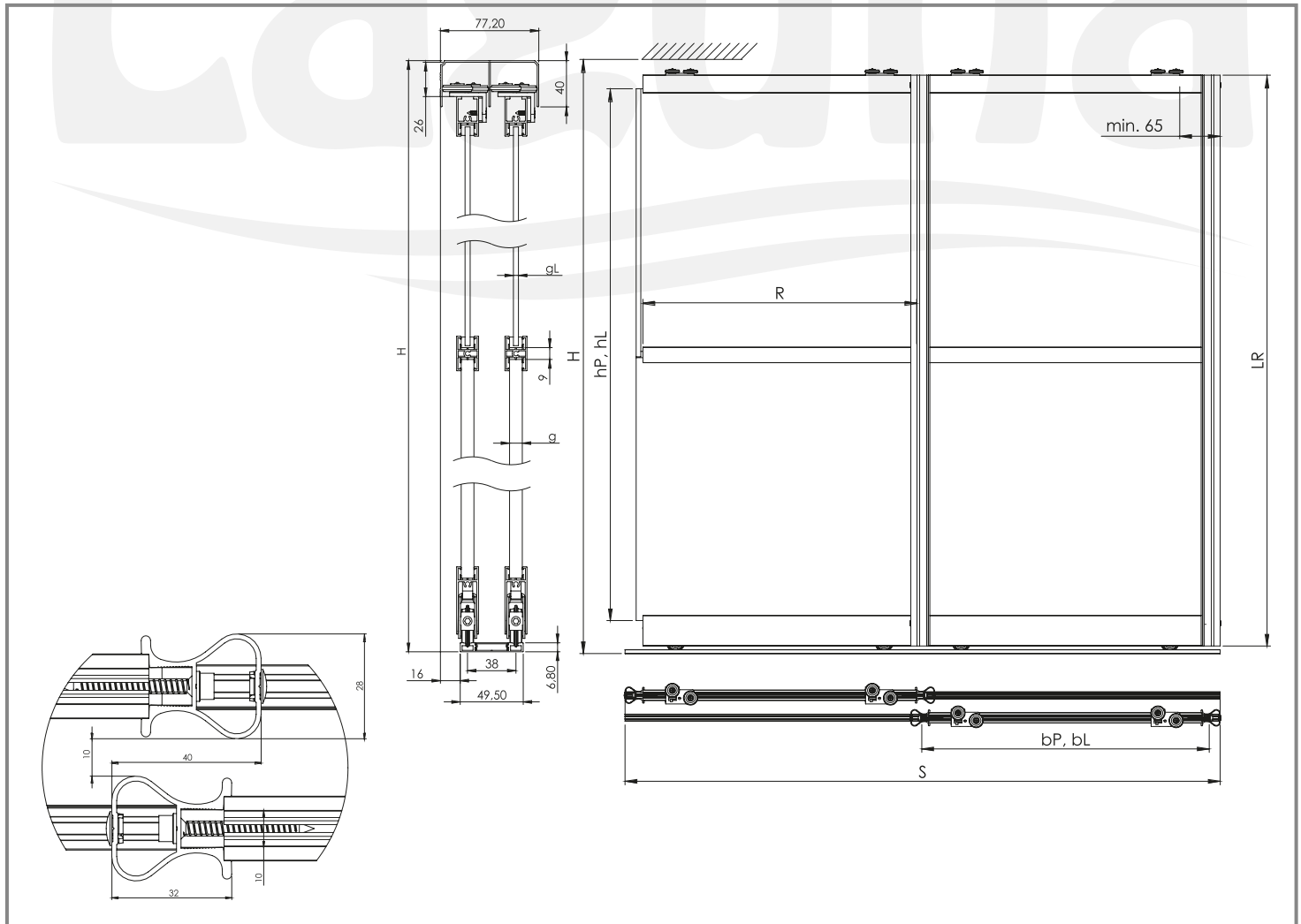

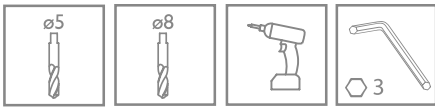

G, K

1

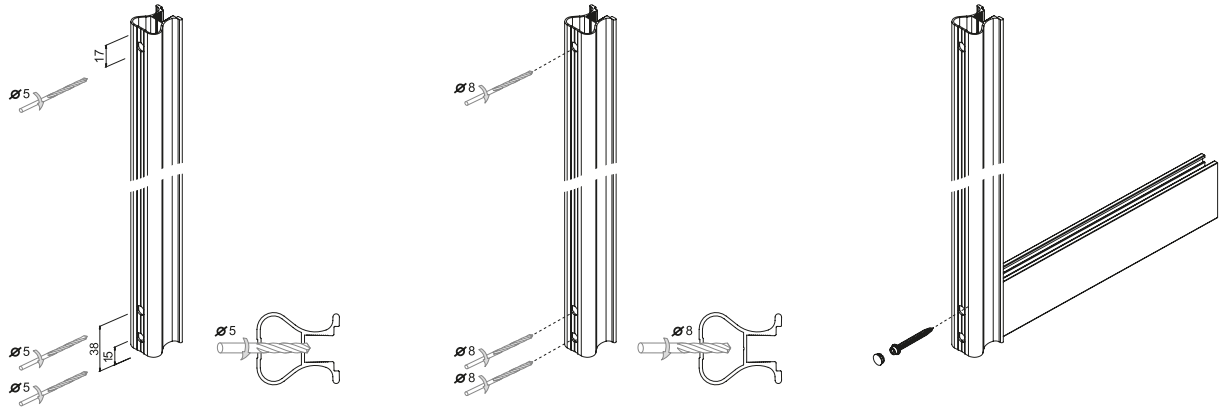

2.1

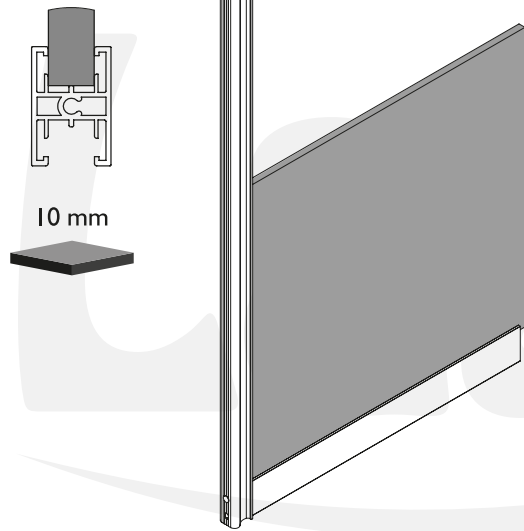

2.2

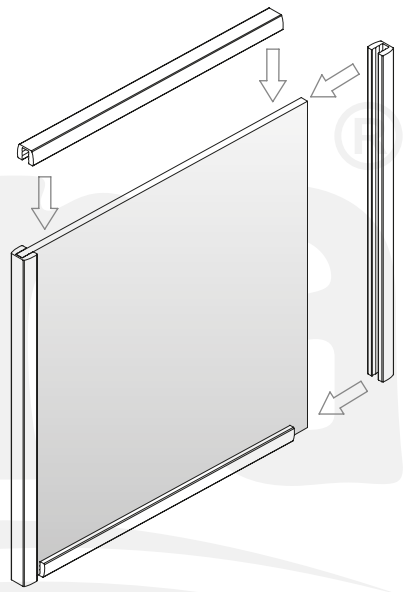
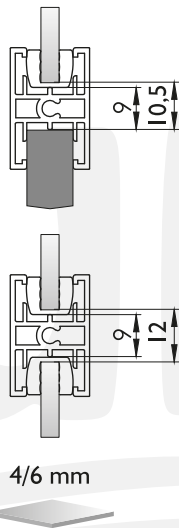
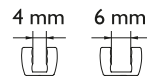

3

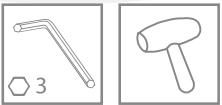

G, K

4

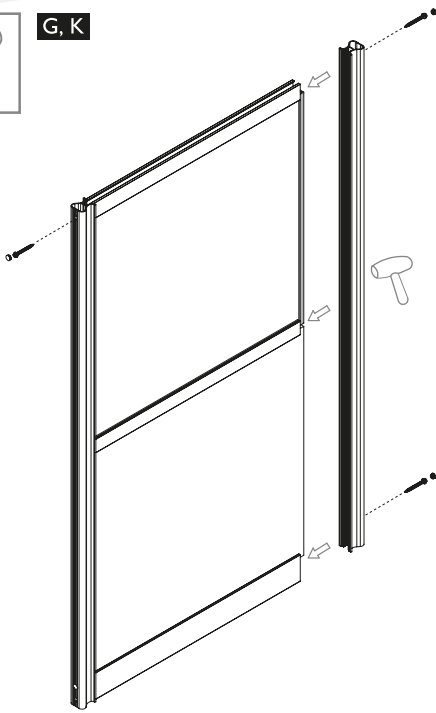
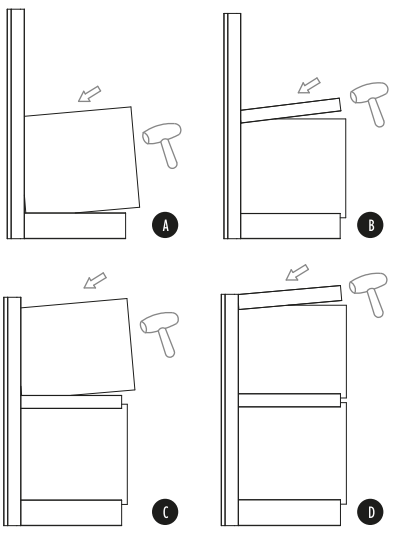



5

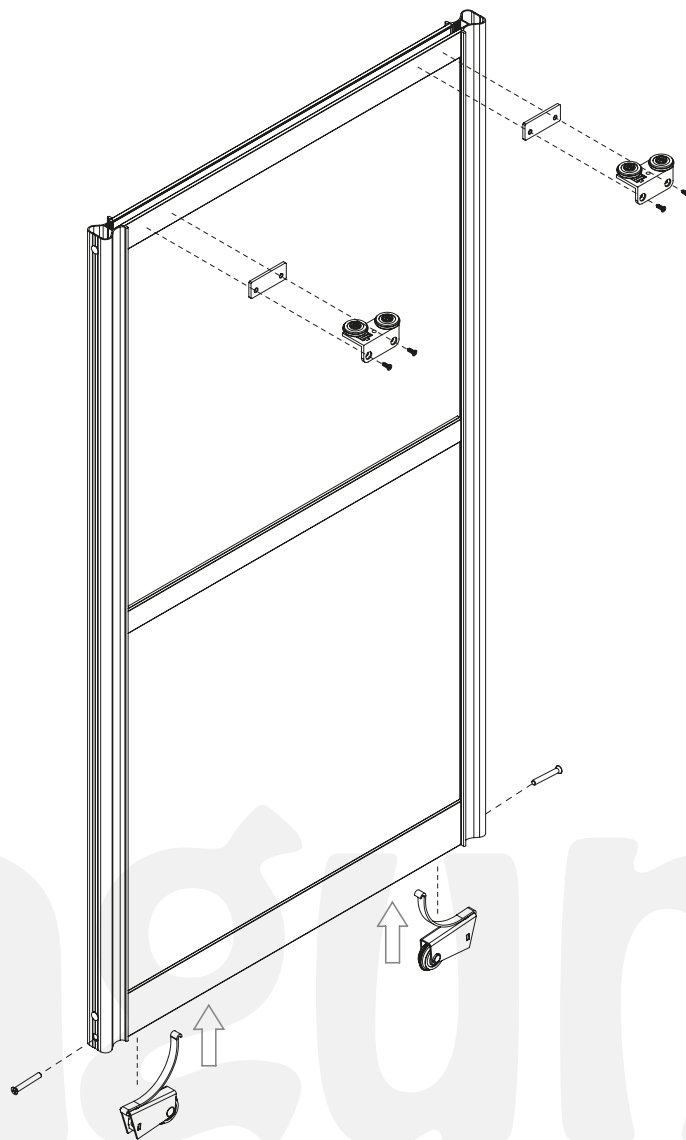

Laguna®

6



L, M

7

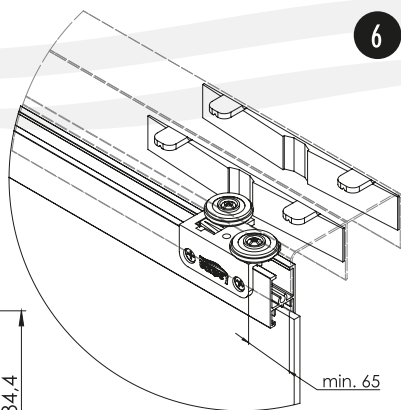

Čelo vestavby
Front building

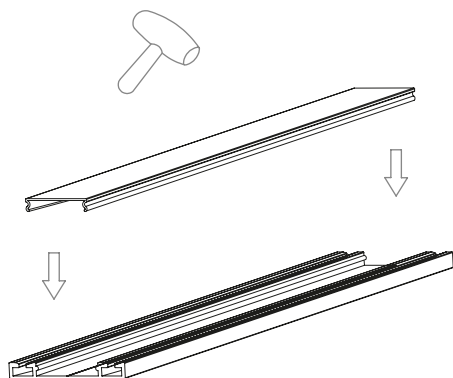
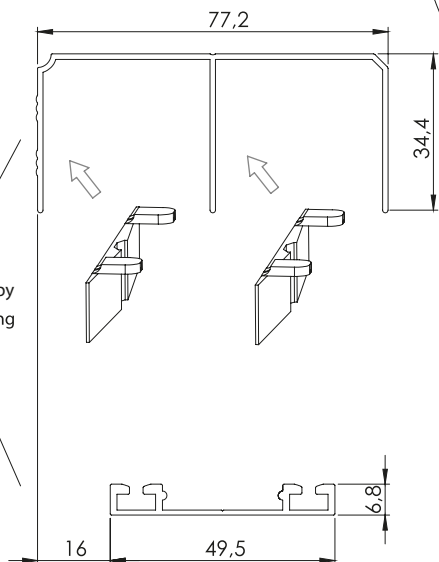

8

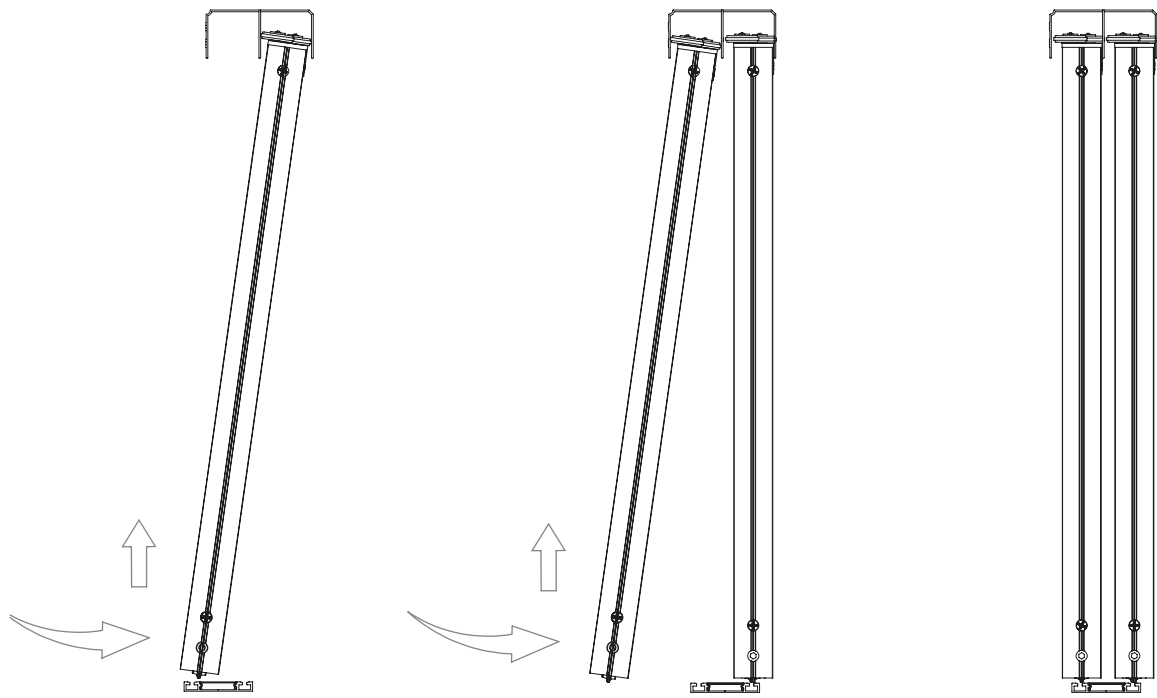

9

