

RAMA WIDE

na torze RAMA z okuciem RAMA
lower track RAMA with hardware RAMA

50 kg

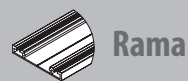

PLYTA | BOARD 18 mm

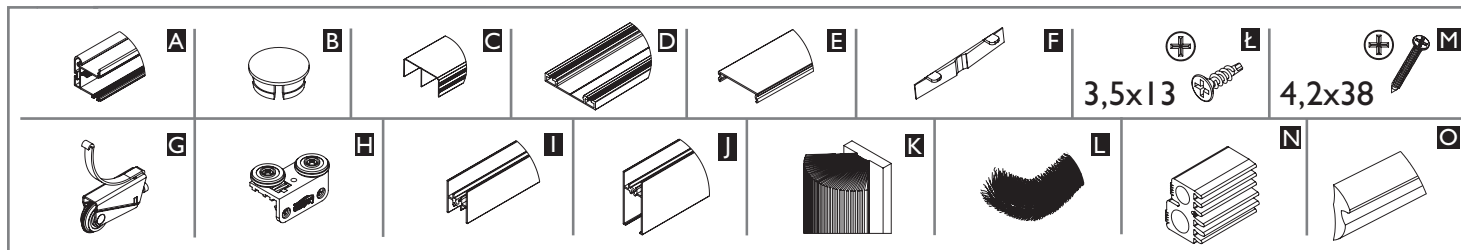
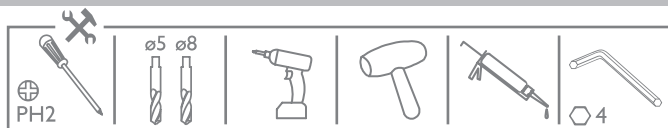

18 mm	Liczba skrzydeł n / Quantity of doors n	n = 2	n = 3	n = 4	n = 5	n = 6	n = 7	n = 8
	 Wysokość płyty hP [mm] / Board height hP [mm] Szerokość płyty bP [mm] / Board width bP [mm] Długość ramiaka dolnego, górnego oraz łącznika R [mm] Upper, lower rail and connector lenght R [mm] Długość rączki LR [mm] / Handle lenght LR [mm]	hP = H-121	$bP = (S-21)/2$	$bP = (S-15)/3$	$bP = (S-8)/4$	$bP = (S-2)/5$	$bP = (S+4)/6$	$bP = (S+11)/7$
$R = bP-29$								
$LR = H-40$								
 Wysokość płyty hP [mm] / Board height hP [mm] Szerokość płyty bP [mm] / Board width bP [mm] Długość ramiaka dolnego, górnego oraz łącznika R [mm] Upper, lower rail and connector lenght R [mm] Długość rączki LR [mm] / Handle lenght LR [mm]	hP = H-121	$bP = (S-21)/2$	$bP = (S-15)/3$	$bP = (S-8)/4$	$bP = (S-2)/5$	$bP = (S+4)/6$	$bP = (S+11)/7$	$bP = (S+17)/8$
	$R = bP-29$							
	$LR = H-40$							
 Wysokość lustra/szklą hL [mm] / Mirror height hL [mm] Szerokość lustra/szklą bL [mm] / Mirror width bL [mm] Długość ramiaka dolnego, górnego oraz łącznika R [mm] Upper, lower rail and connector lenght R [mm] Długość rączki LR [mm] / Handle lenght LR [mm]	hL = H-112	$bL = (S-3)/2$	$bL = (S+12)/3$	$bL = (S+27)/4$	$bL = (S+43)/5$	$bL = (S+58)/6$	$bL = (S+74)/7$	$bL = (S+89)/8$
	$R = bL-38$							
	$LR = H-40$							

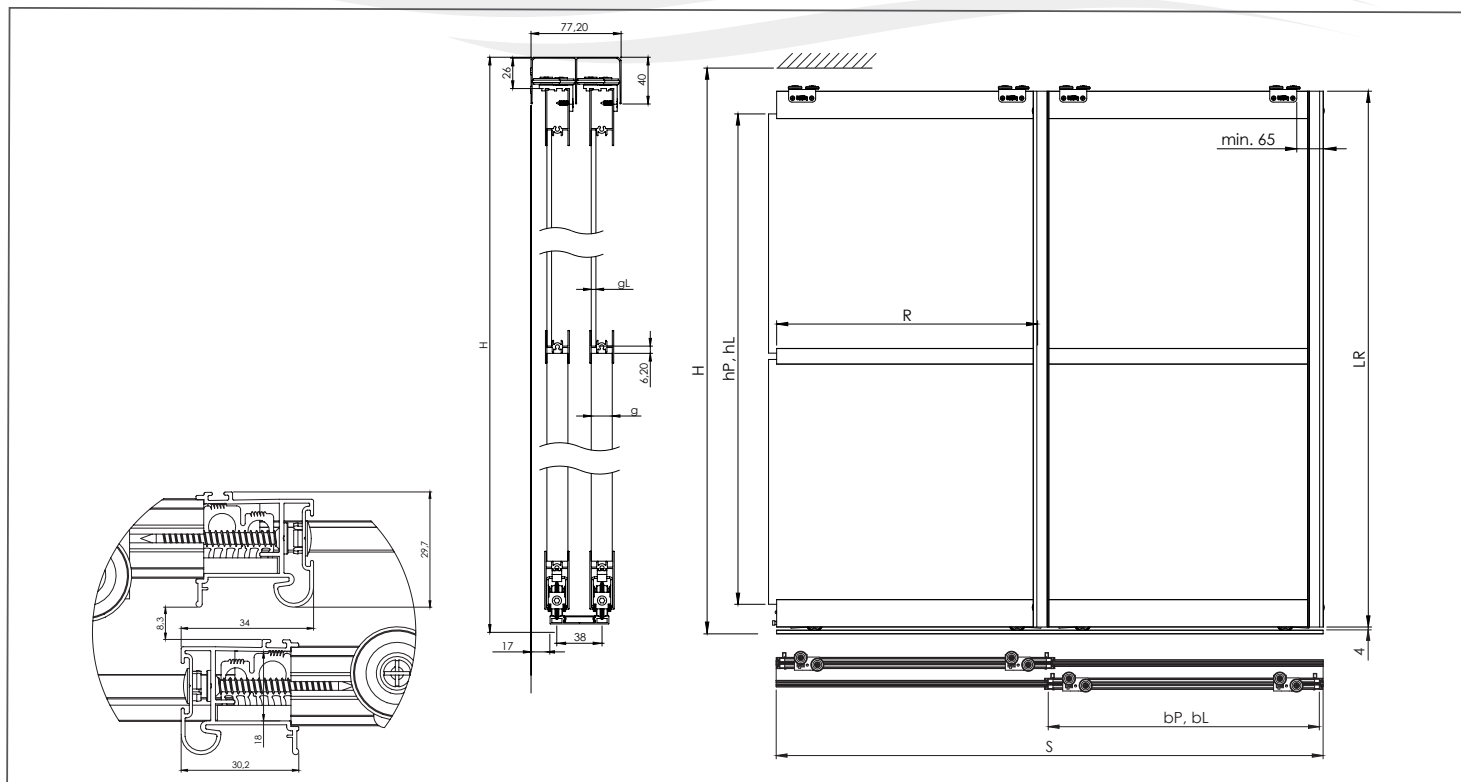

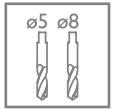

A, J, B, M

1

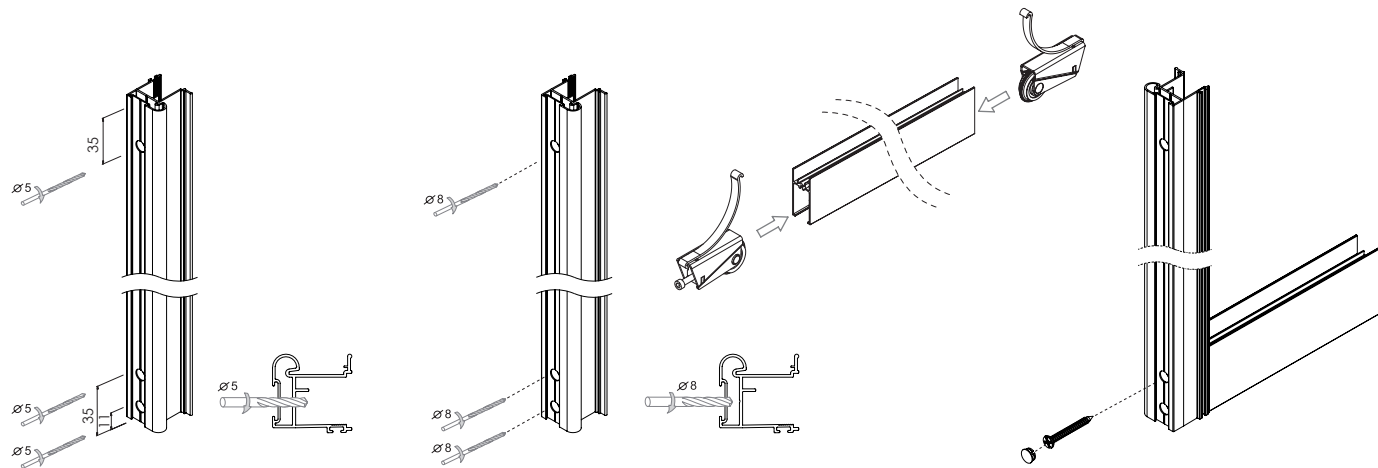

I, A

2.1

I, A

2.2

I, A

2.3

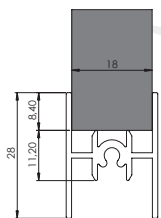

18 mm

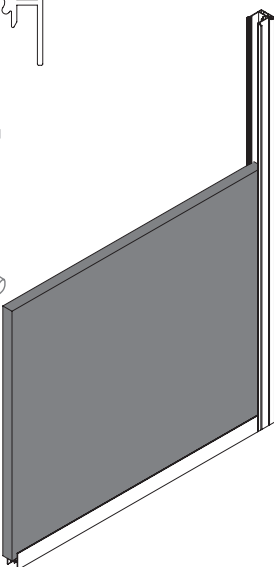

8815

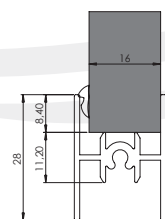

16 mm

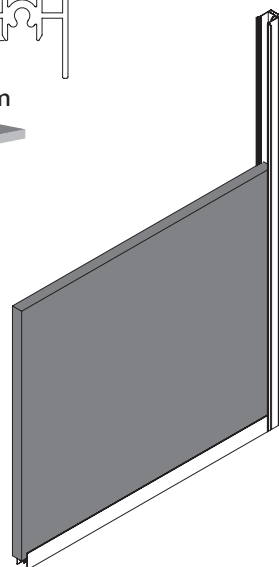

8176

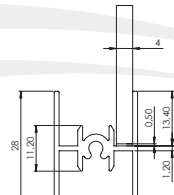

4 mm

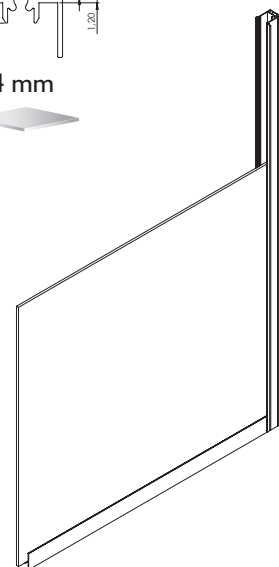

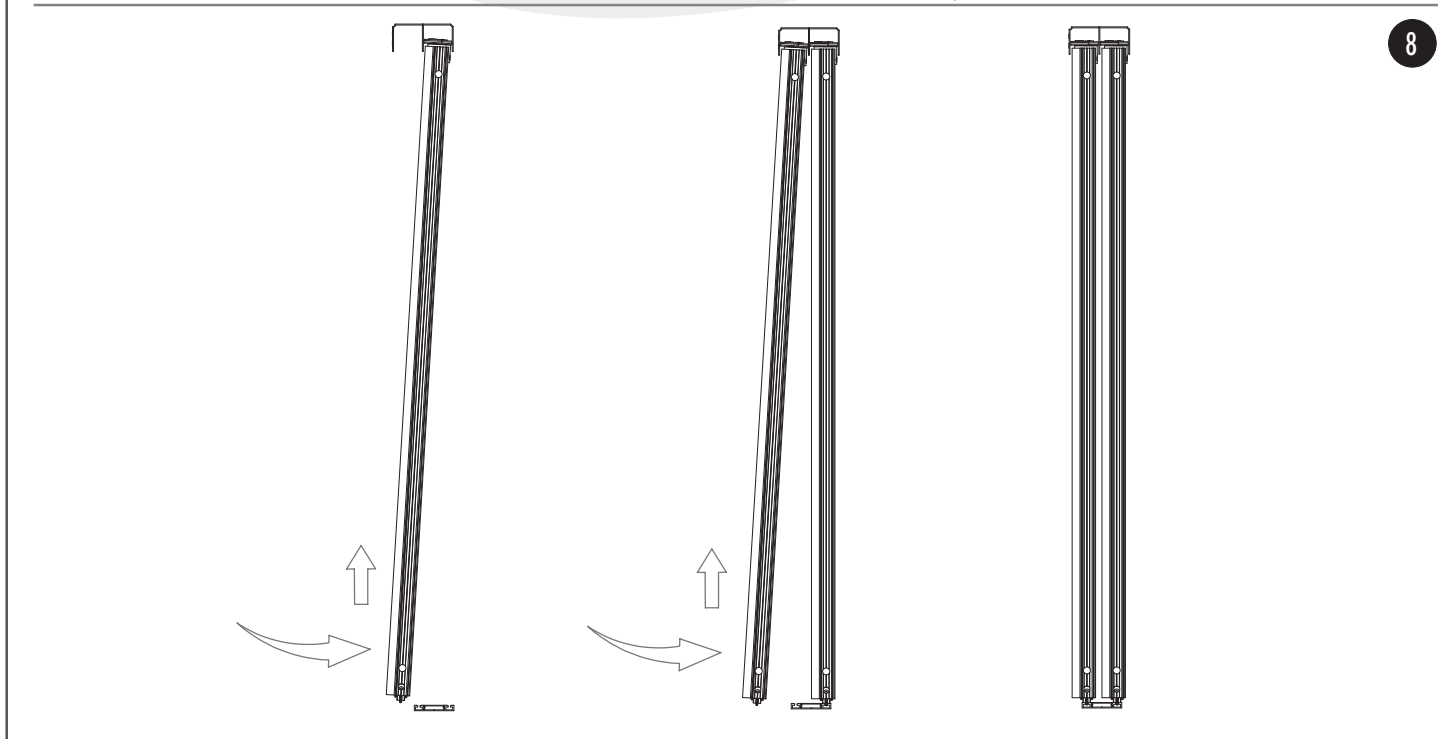
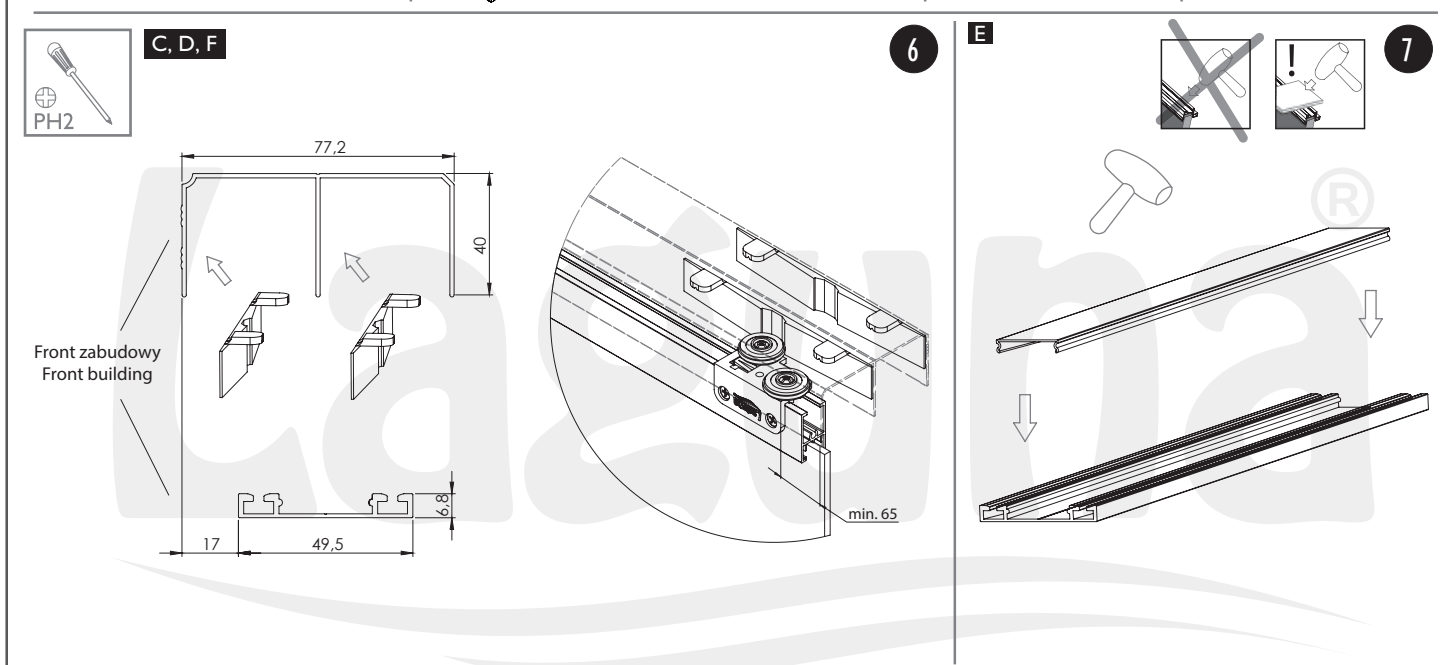
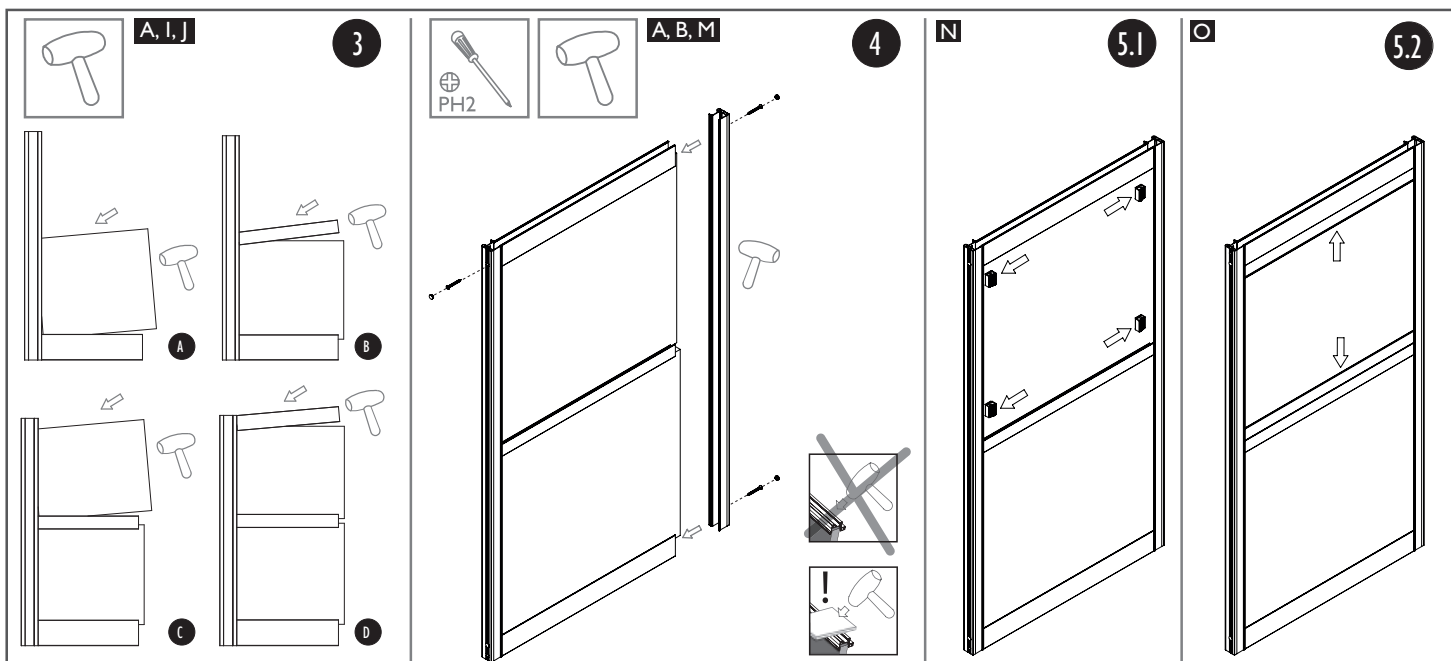

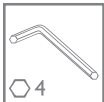

K, L

9

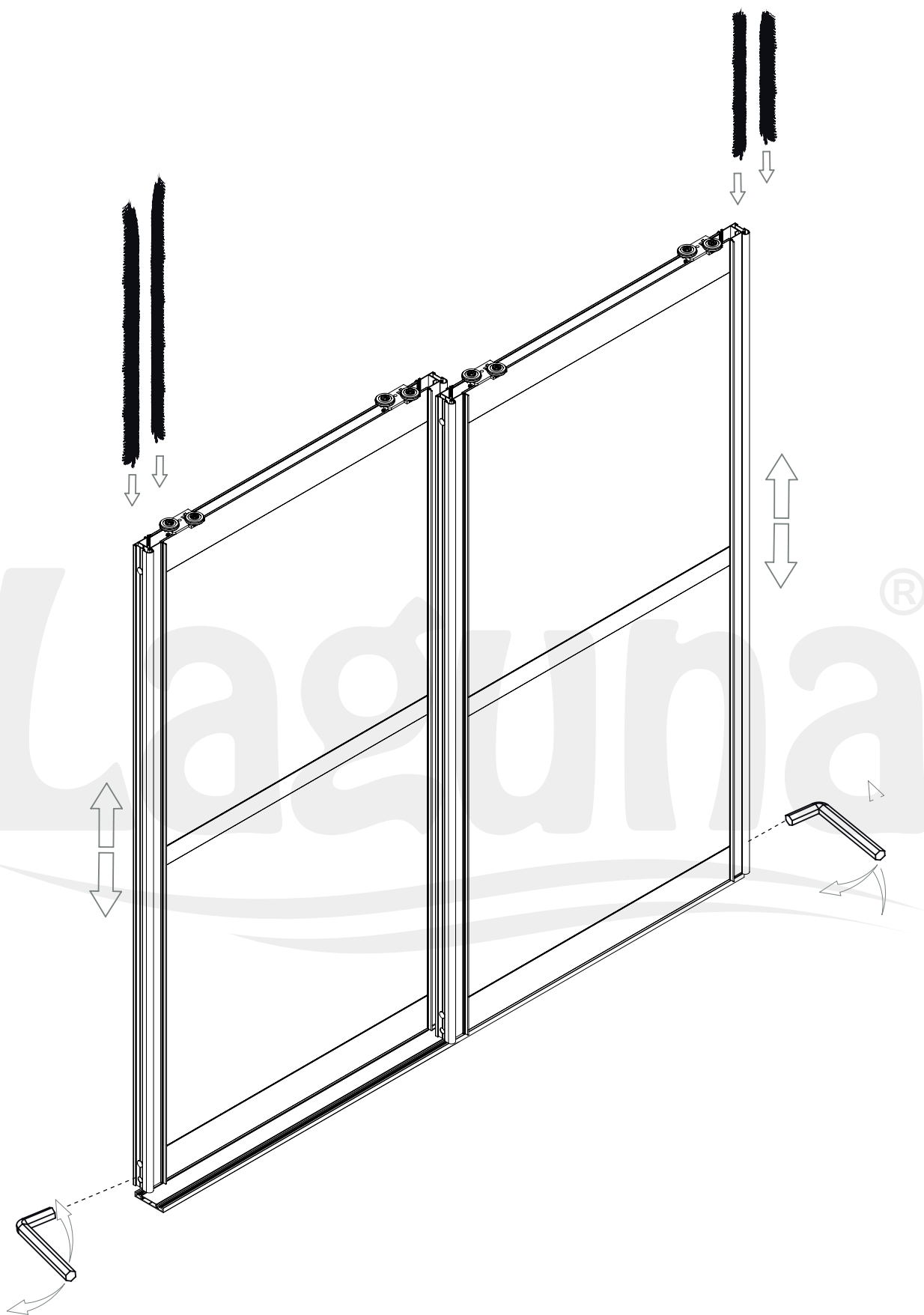

Zaleca się postępowanie zgodnie z niniejszą instrukcją przy użyciu odpowiednich narzędzi, zgodnych ze wskazaniami. W przypadku elementów, których powierzchnia może być ostra należy stosować środki ochrony indywidualnej oraz zabezpieczenie obszaru pracy. Firma Laguna Fabryka Okuć Sp. z o.o. Sp. k. uchyli się od odpowiedzialności za działania wynikające z postępowania niezgodnego z niniejszą instrukcją.

It is recommended that you follow these instructions using the appropriate tools as indicated. In the case of elements whose surface can be sharp, use personal protective equipment and work area protection. The company Laguna Hardware Factory Limited Liability Limited Partnership refrains from liability for actions resulting from conduct incompatible with this instruction.