

www.salu.cz

SALU Systems, s.r.o.
739 91 Jablunkov
Žihla 992
tel./fax: 558 326 377

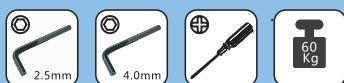
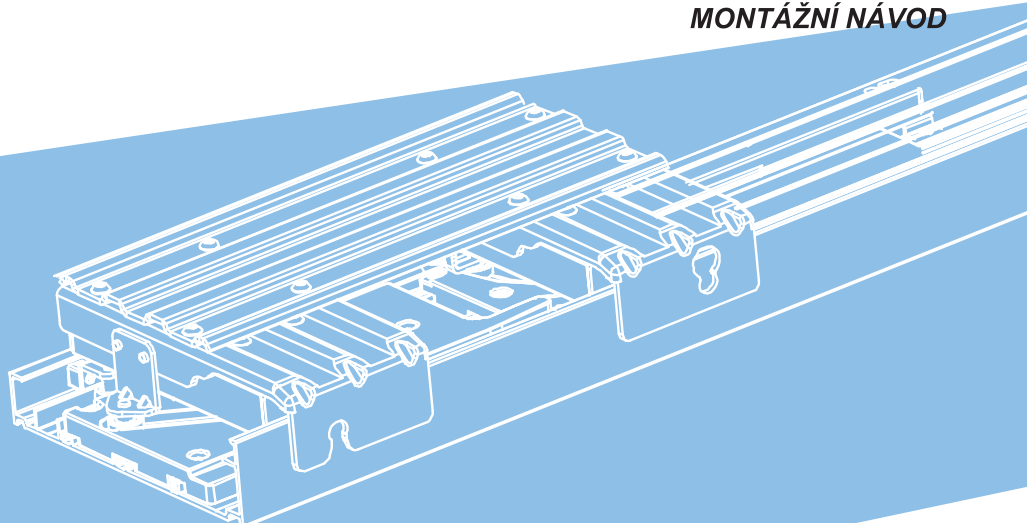

PŘÍSLUŠENSTVÍ

horní kolejnice
1x

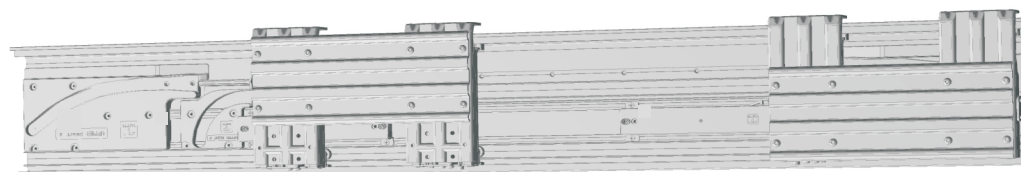

dolní kolejnice
1x

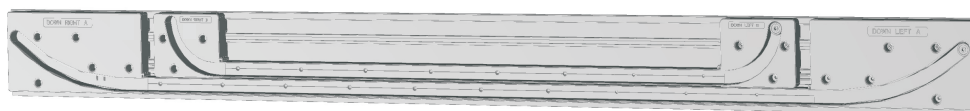

nastavovací
deska A
2x

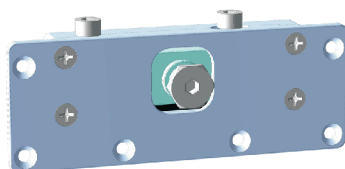

nastavovací
deska B
2x

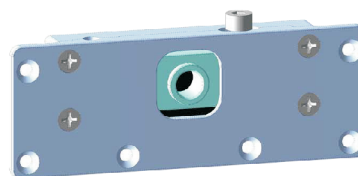

dolní upevňovací část
2x

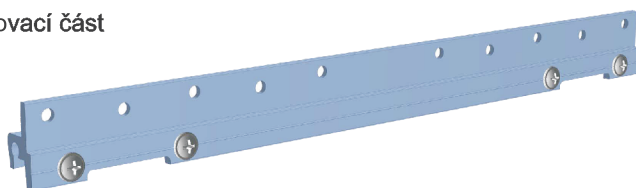

dolní fixační díl
8x

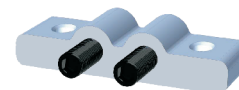

dolní běžec A
1x

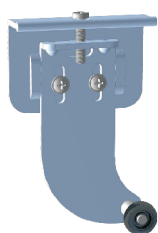

dolní běžec B
1x

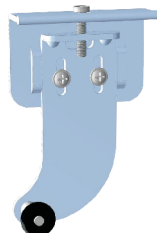

dolní běžec C
2x



dolní kolejová
fixační destička
8x

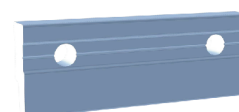

vrut 4x20mm
32x



vrut 4x16mm
60x



imbusový klíč
2,5 mm
1x



imbusový klíč
4 mm
1x



pomocná šablona
k vrtání dírek
1x



klíč
1x



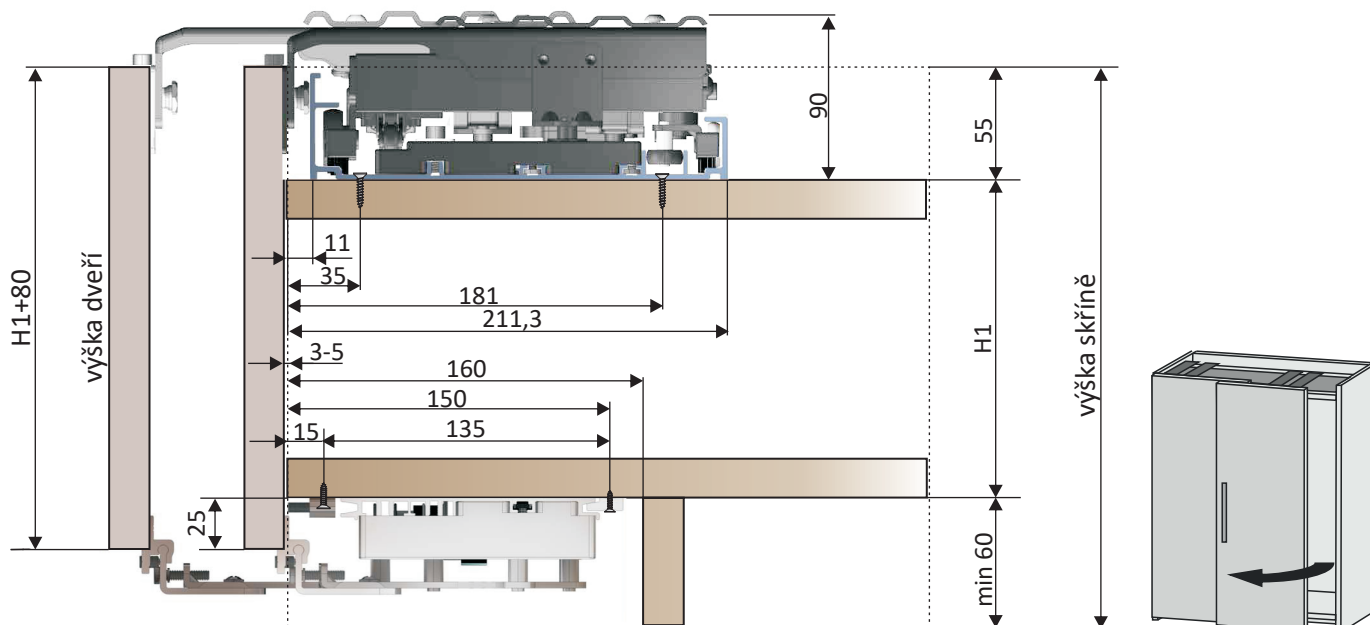

Tloušťka dveří 18 - 45 mm (úchytková součást)

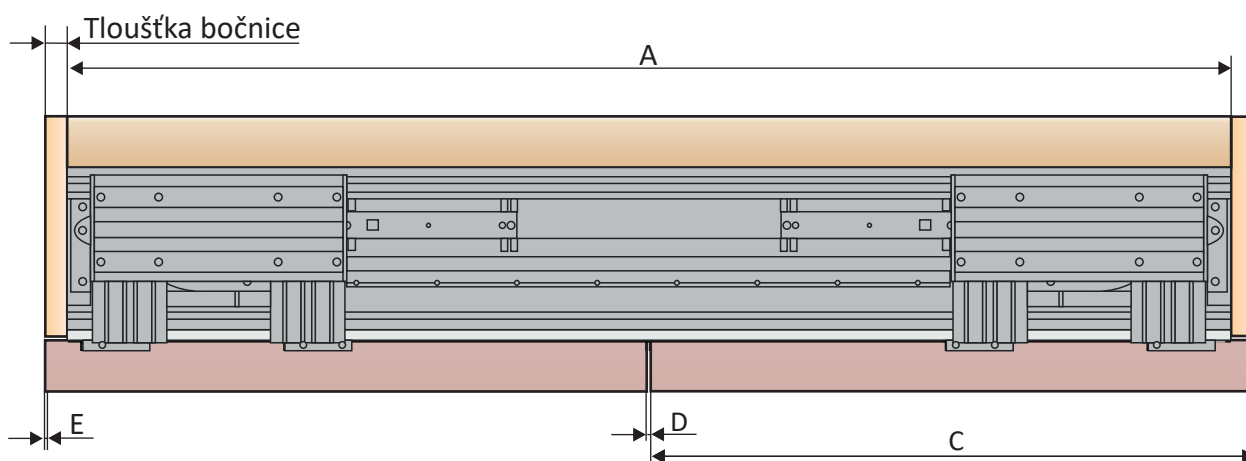

A = vnitřní šířka skříně
E = mezera mezi bočnicí a dveřmi

D = mezera mezi dveřmi (3-5mm)

C = šířka dveří $\frac{A+2T-2E-D}{2}$

1.1.Specifikace skříně

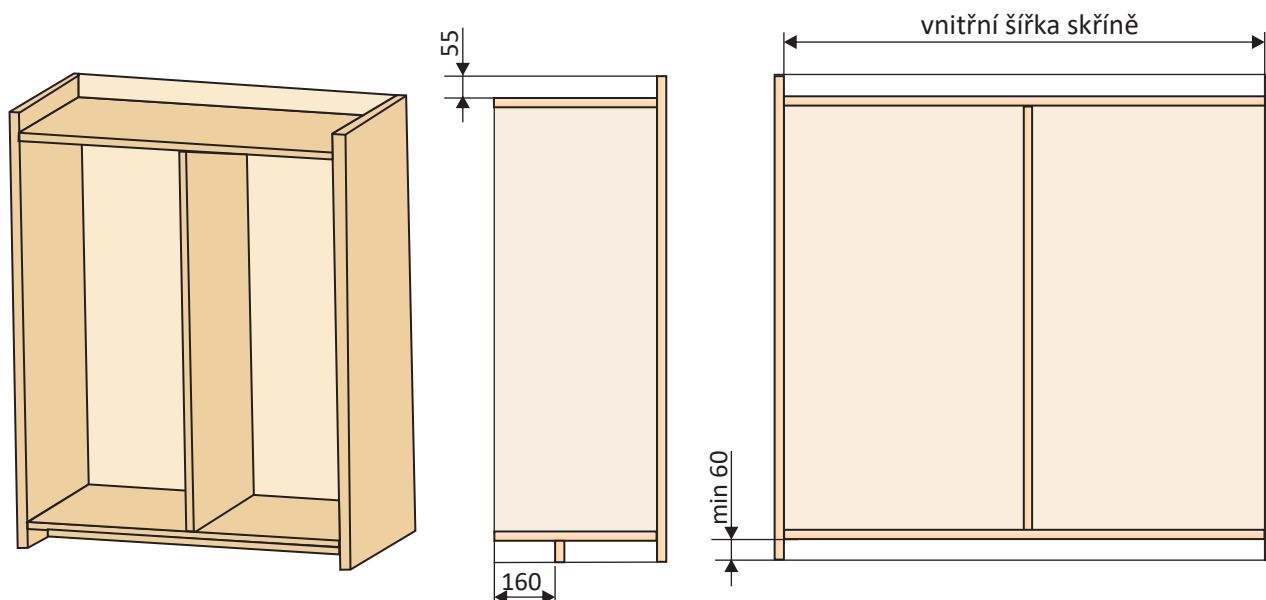

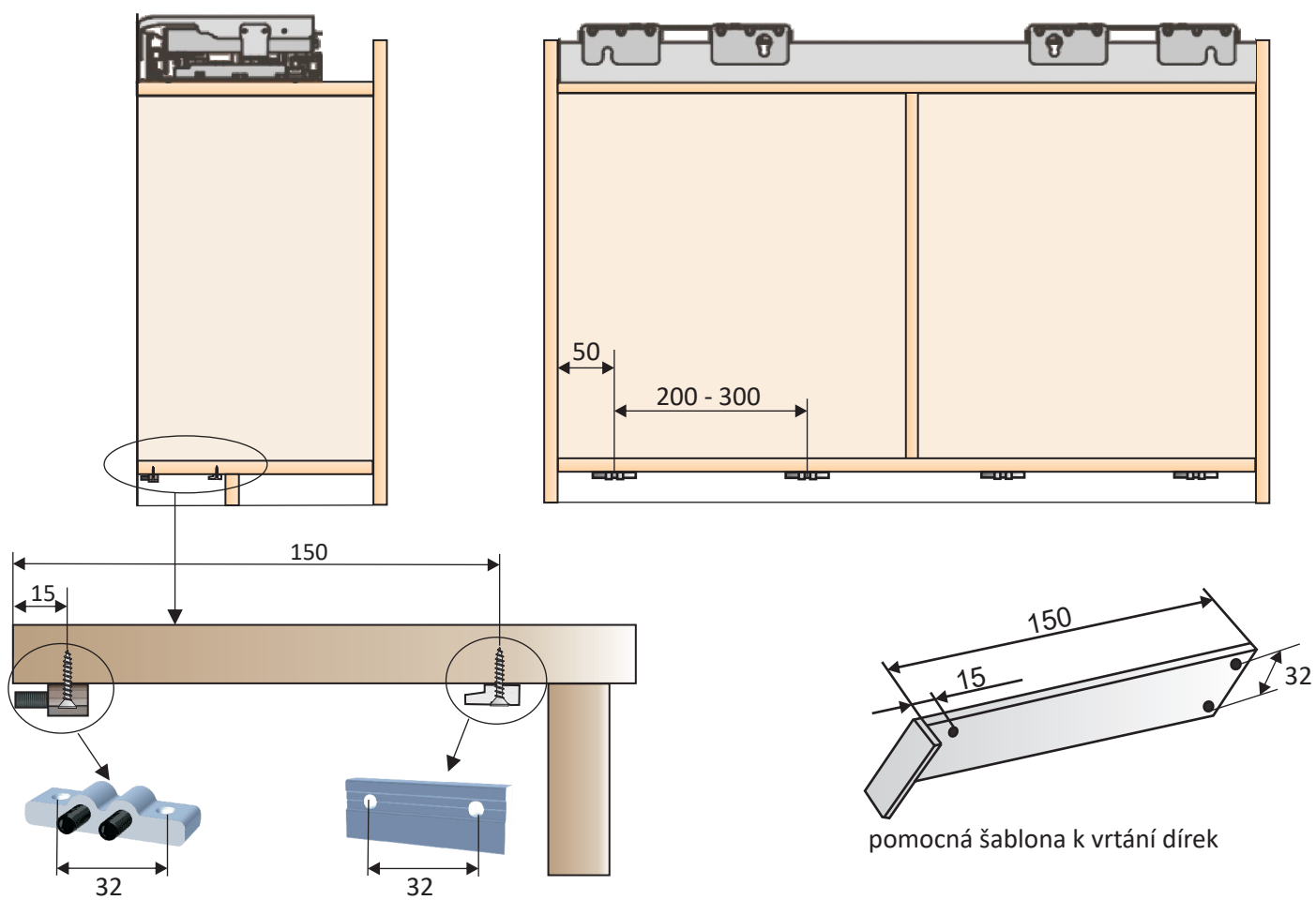

3. Instalace dolní kolejnice

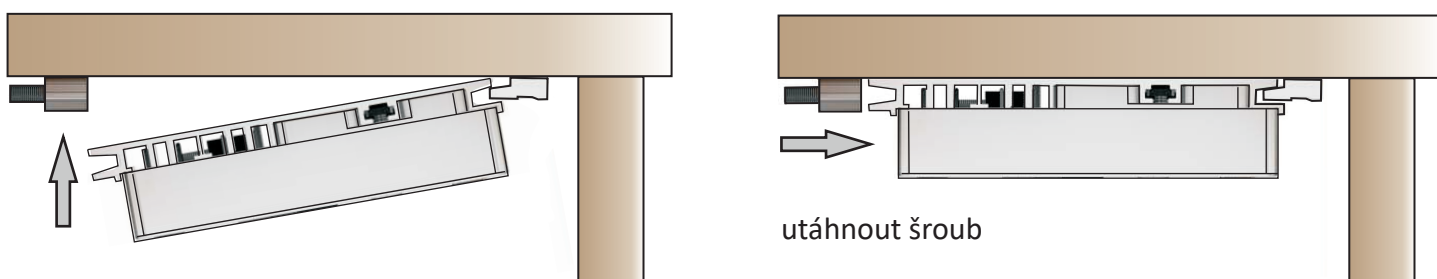

4. Instalace horní kolejnice

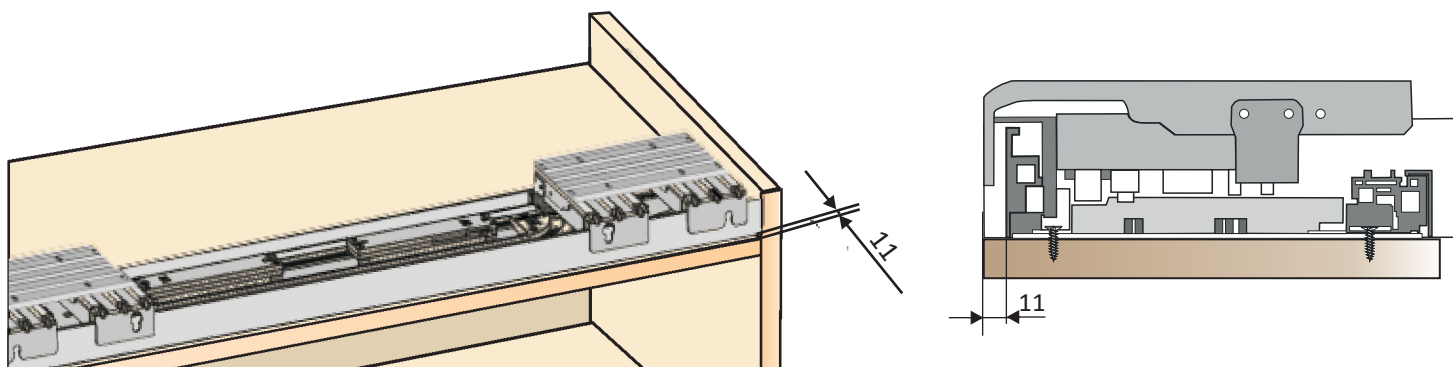

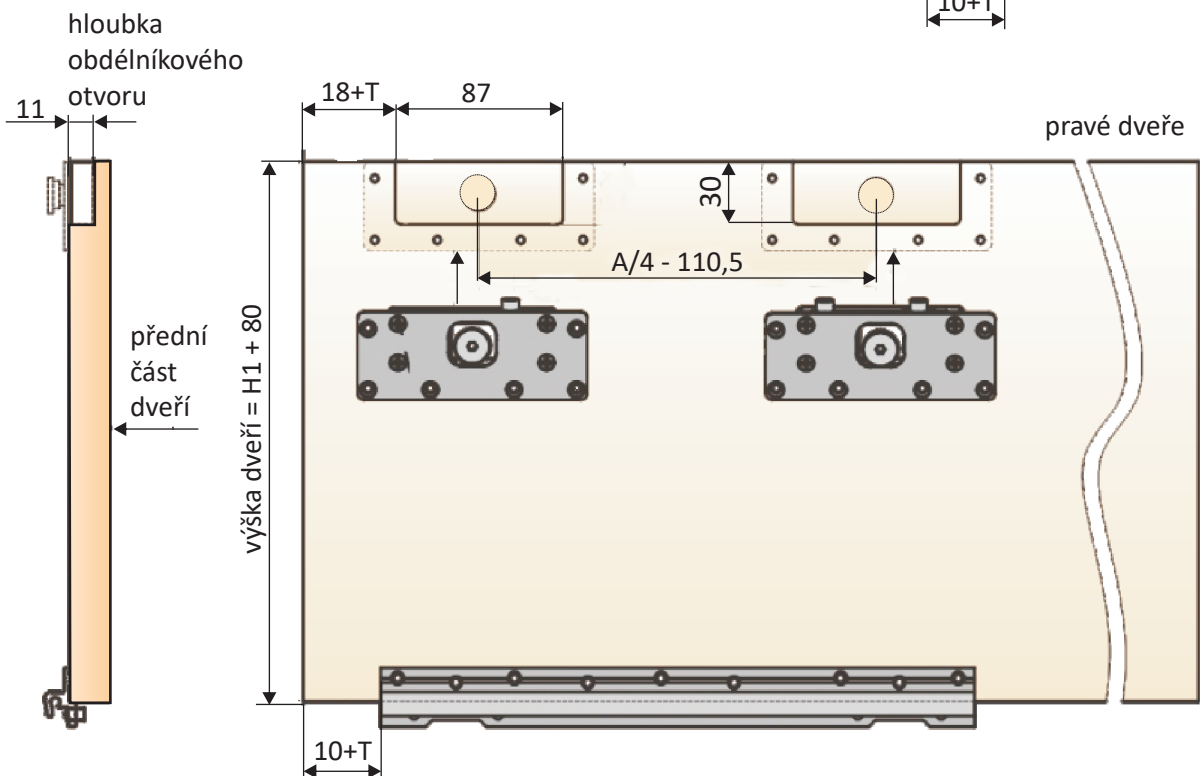
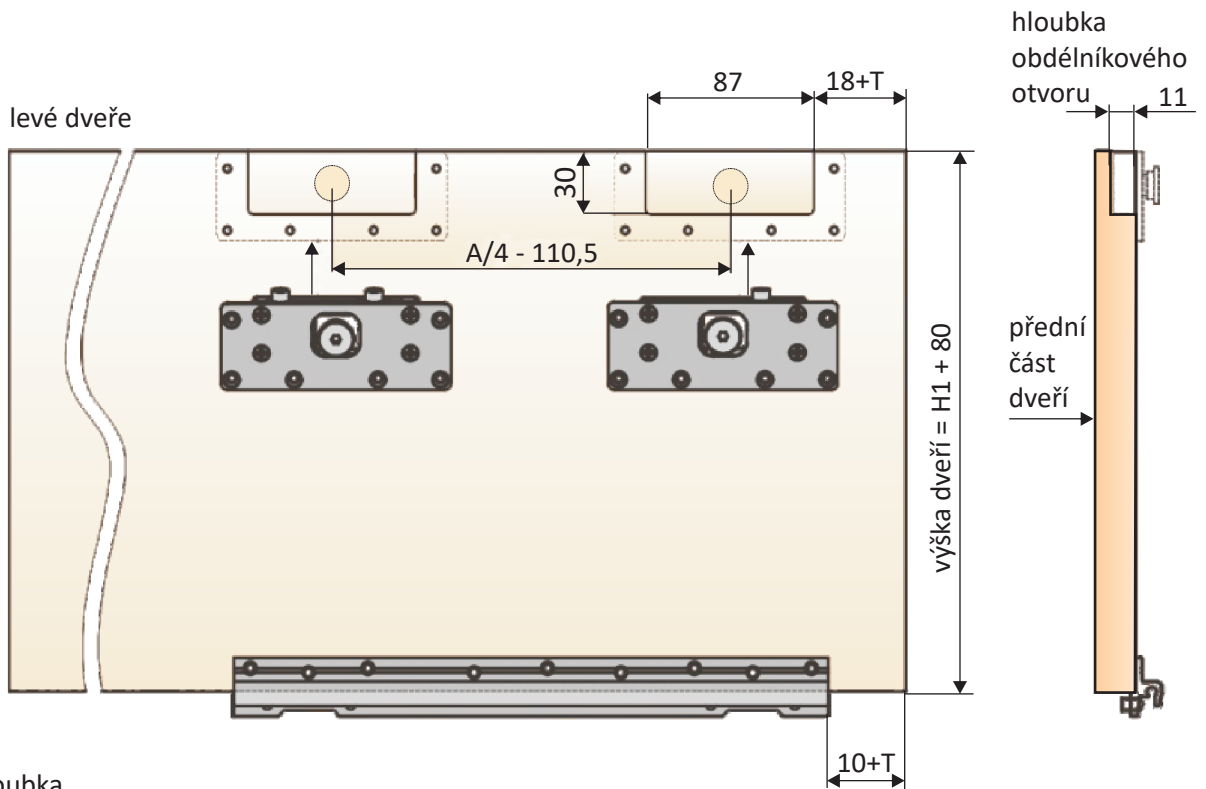
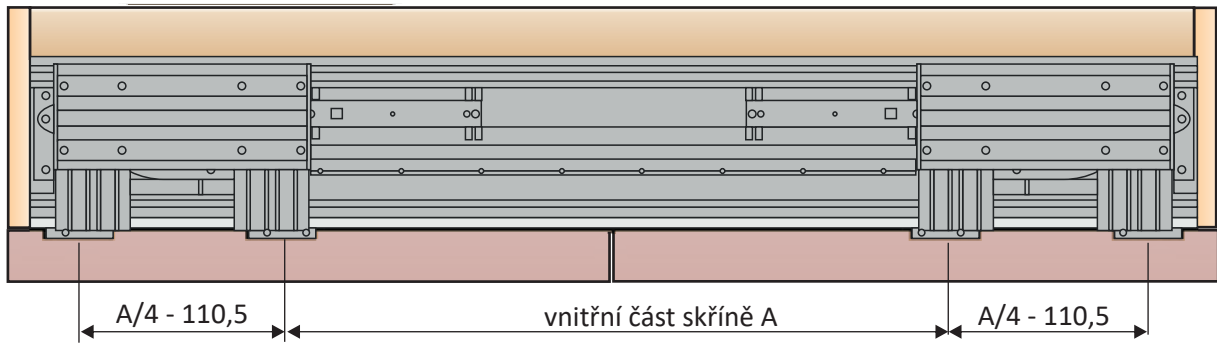

6. Pravou horní lištu posuňte do střední části, zavěšte šroub do otvoru

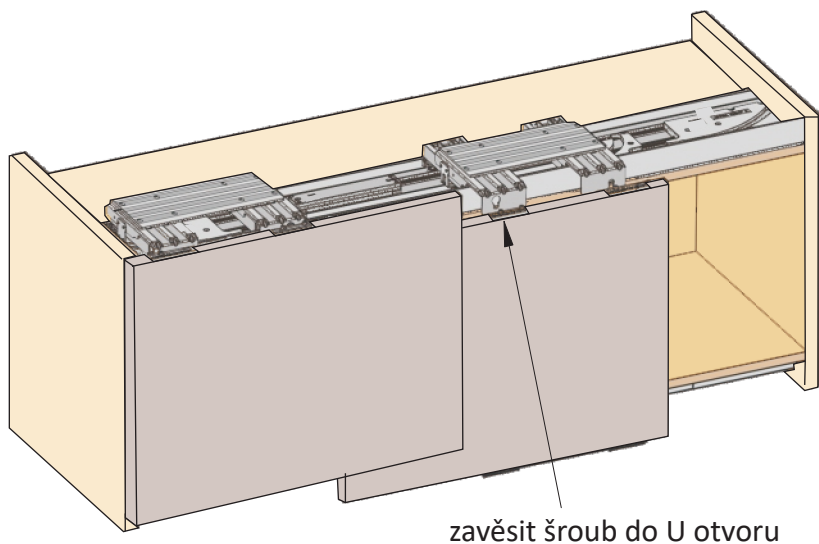

6.1. Zavěšení šroubu do U otvoru

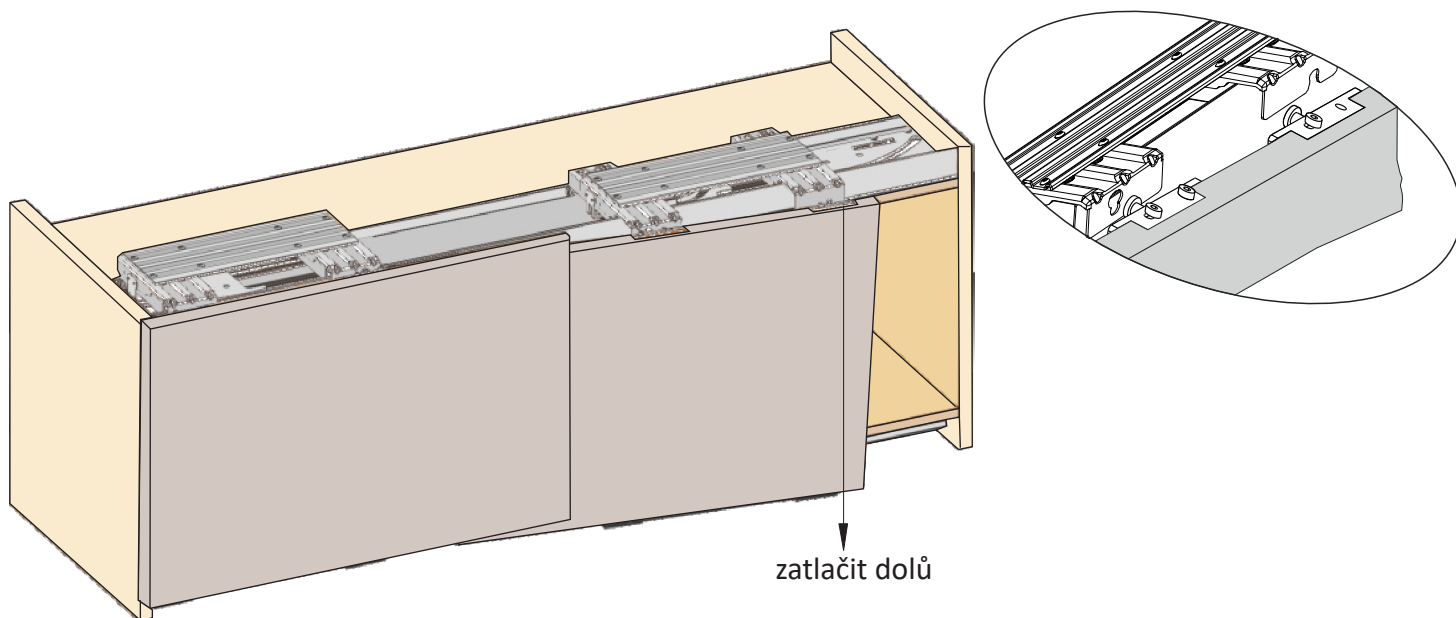

6.2. Dotažení imbusovým klíčem / klíčem

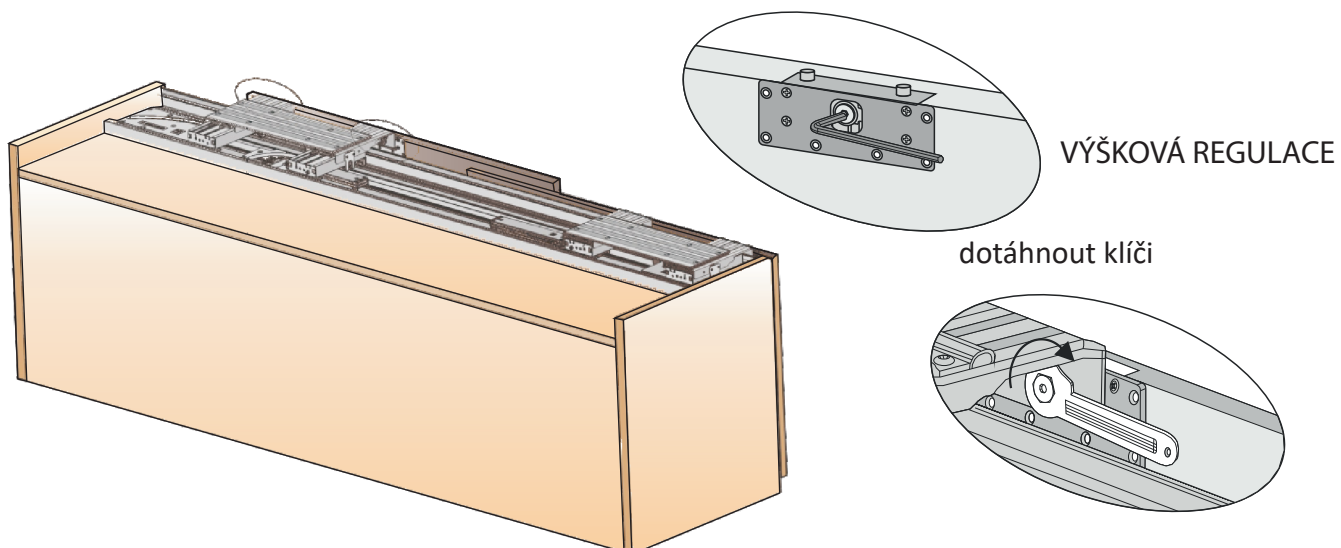

dolní kolečko levých dveří

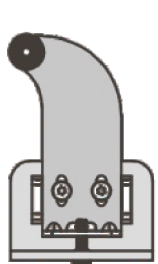

dolní kolečko A

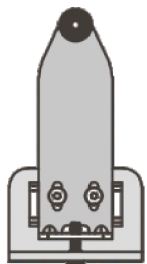

dolní kolečko C

dolní kolečko pravých dveří

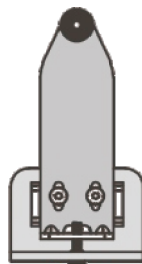

dolní kolečko C

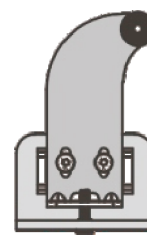

dolní kolečko B



7.1. Nasadíte spodní vodítko pravých dveří na spodní upevňovací desku, nejprve instalujte běhoun C, poté nainstalujte běhoun B

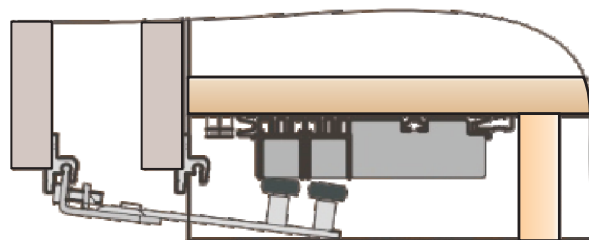
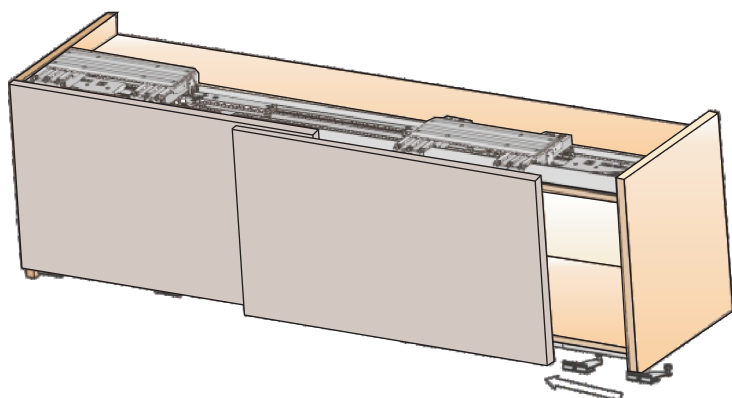

7.2. Utáhněte šroub a nechte kolečka zapadnout do kolejníc

7.3. Zavřete dveře

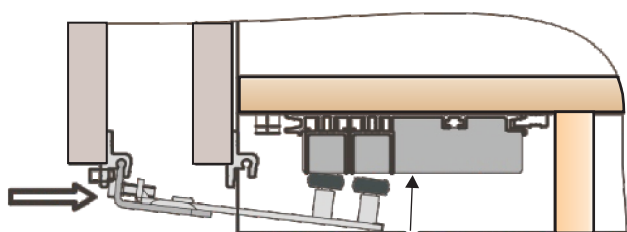

můžete posunout a zavřít dveře

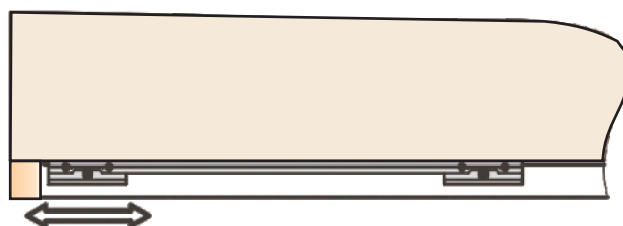

7.4. Nastavení mezery mezi bočnicí a dveřmi

7.5. Otevřete dveře a dotáhněte

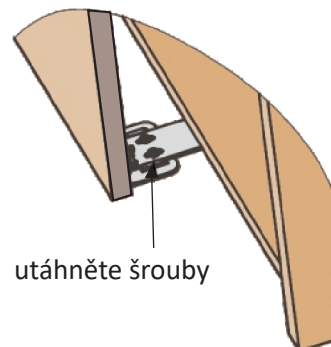
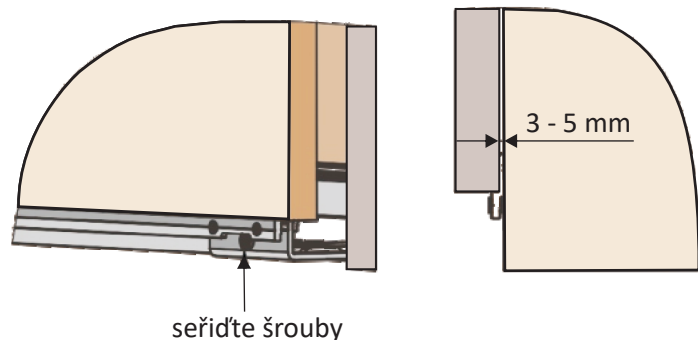

seřídte šrouby

utáhněte šrouby

stejný postup i u levých dveří

8. Nastavení výšky dveří

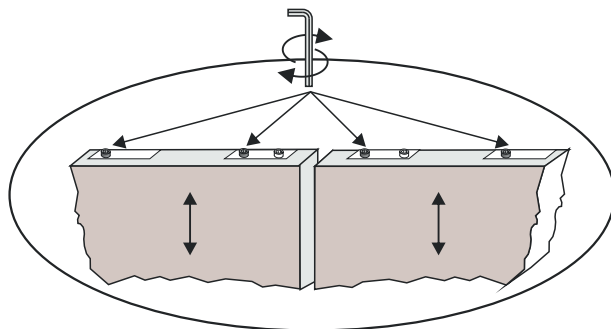
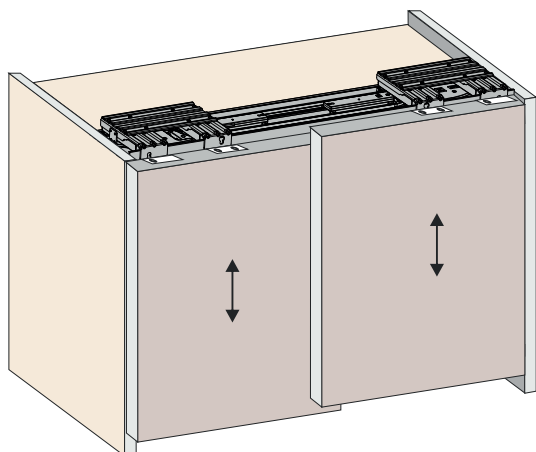

9. Úprava mezery mezi dveřmi

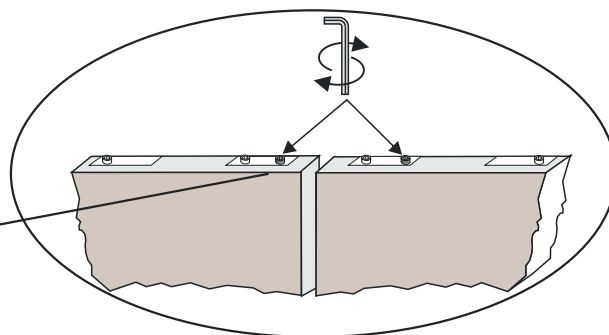
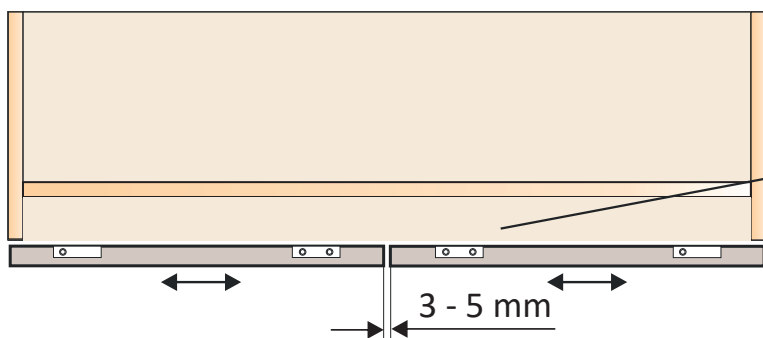

10. Otevřít dveře a nastavit tlumič

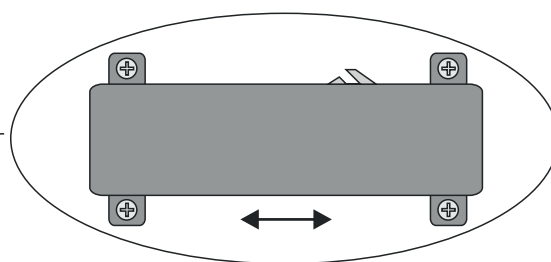
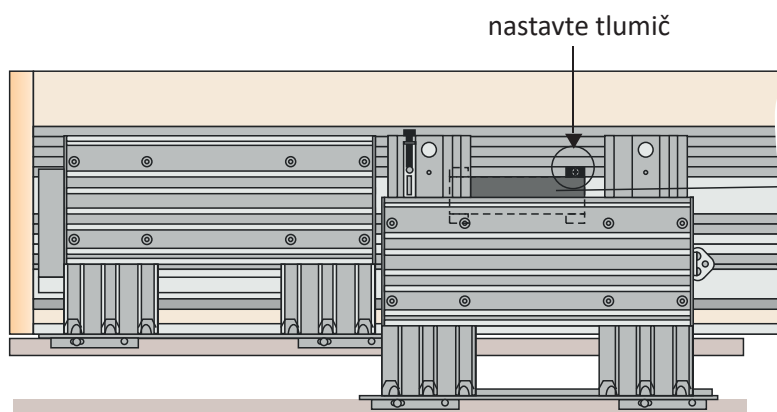

11. Zavřete dveře, upravte pružinu tak, aby se dveře správně zavřely

